

# Full Adder

Inputs from Left and Right Busses into the ALU

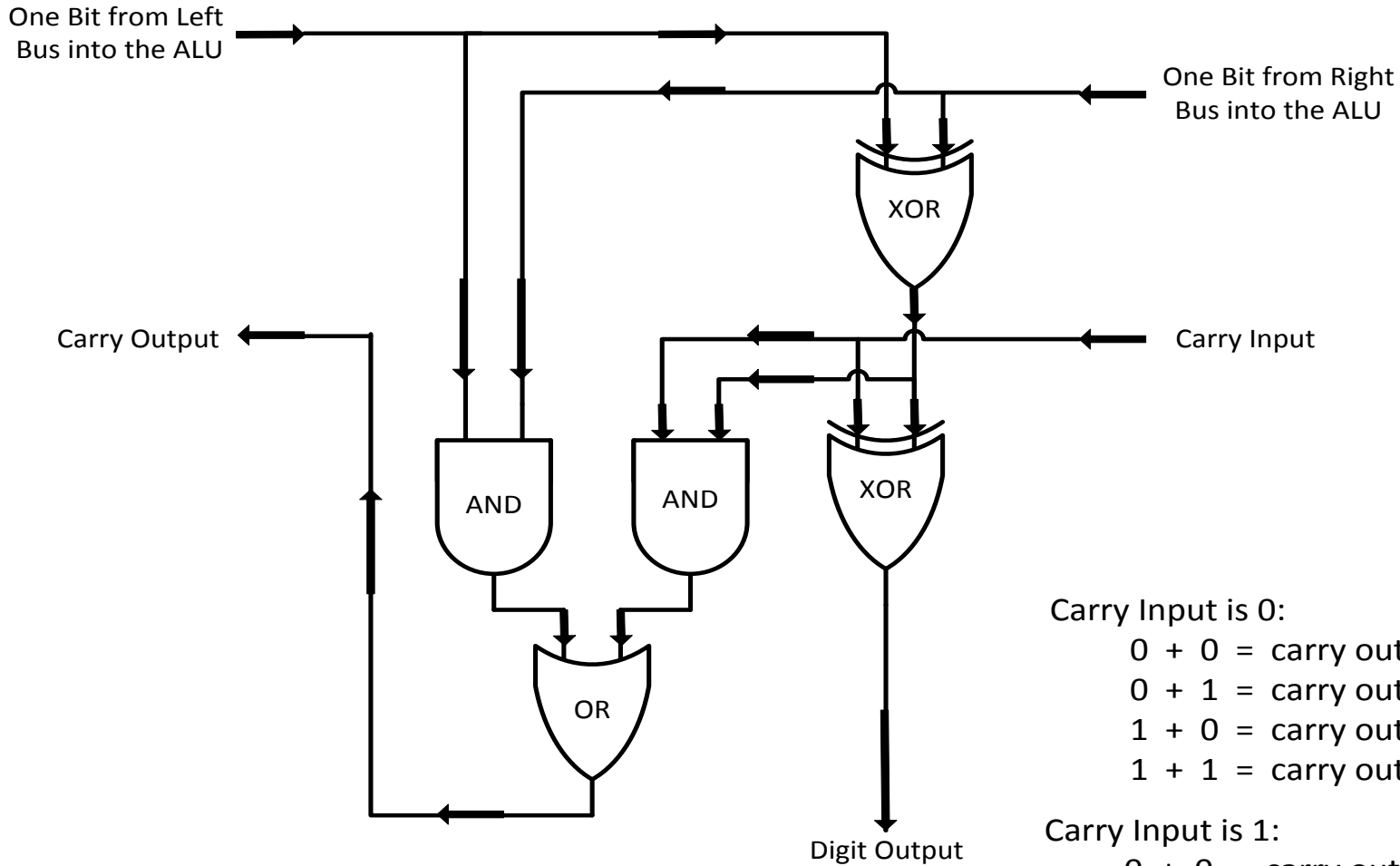

O u t p u t

Conforms to the Binary Addition Results →

Carry Input is 0:

$0 + 0 = \text{carry out } 0 \text{ and sum digit } 0$

$0 + 1 = \text{carry out } 0 \text{ and sum digit } 1$

$1 + 0 = \text{carry out } 0 \text{ and sum digit } 1$

$1 + 1 = \text{carry out } 1 \text{ and sum digit } 0$

Carry Input is 1:

$0 + 0 = \text{carry out } 0 \text{ and sum digit } 1$

$0 + 1 = \text{carry out } 1 \text{ and sum digit } 0$

$1 + 0 = \text{carry out } 1 \text{ and sum digit } 0$

$1 + 1 = \text{carry out } 1 \text{ and sum digit } 1$

# Full Adder

Inputs from Left and Right Buses into the ALU

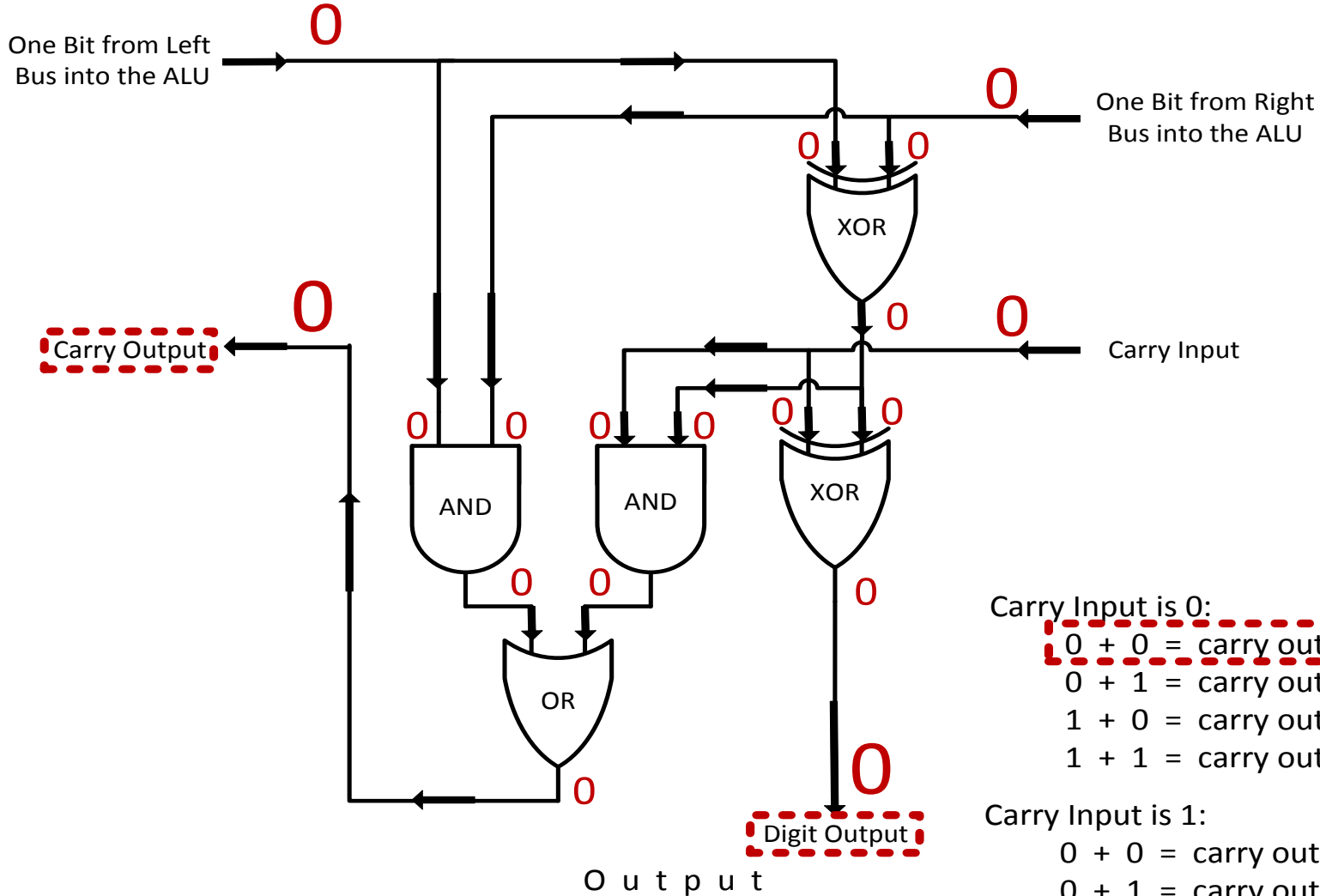

Carry Input is 0:

$0 + 0 = \text{carry out } 0 \text{ and sum digit } 0$

$0 + 1 = \text{carry out } 0 \text{ and sum digit } 1$

$1 + 0 = \text{carry out } 0 \text{ and sum digit } 1$

$1 + 1 = \text{carry out } 1 \text{ and sum digit } 0$

Carry Input is 1:

$0 + 0 = \text{carry out } 0 \text{ and sum digit } 1$

$0 + 1 = \text{carry out } 1 \text{ and sum digit } 0$

$1 + 0 = \text{carry out } 1 \text{ and sum digit } 0$

$1 + 1 = \text{carry out } 1 \text{ and sum digit } 1$

Conforms to the Binary Addition Results →

# Full Adder

Inputs from Left and Right Buses into the ALU

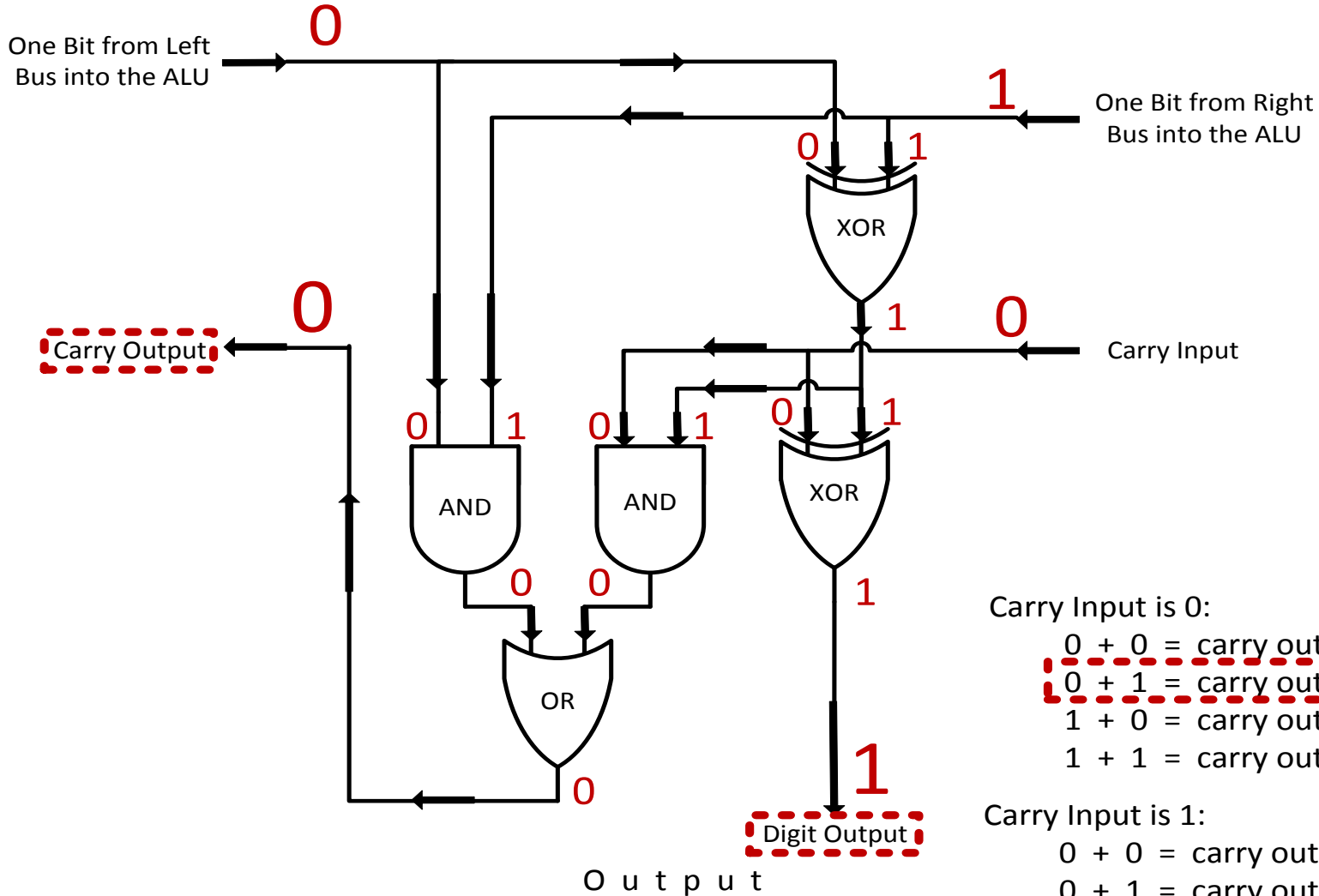

Carry Input is 0:

- $0 + 0 = \text{carry out } 0 \text{ and sum digit } 0$
- $0 + 1 = \text{carry out } 0 \text{ and sum digit } 1$
- $1 + 0 = \text{carry out } 0 \text{ and sum digit } 1$
- $1 + 1 = \text{carry out } 1 \text{ and sum digit } 0$

Carry Input is 1:

- $0 + 0 = \text{carry out } 0 \text{ and sum digit } 1$
- $0 + 1 = \text{carry out } 1 \text{ and sum digit } 0$
- $1 + 0 = \text{carry out } 1 \text{ and sum digit } 0$
- $1 + 1 = \text{carry out } 1 \text{ and sum digit } 1$

Conforms to the Binary Addition Results →

# Full Adder

Inputs from Left and Right Buses into the ALU

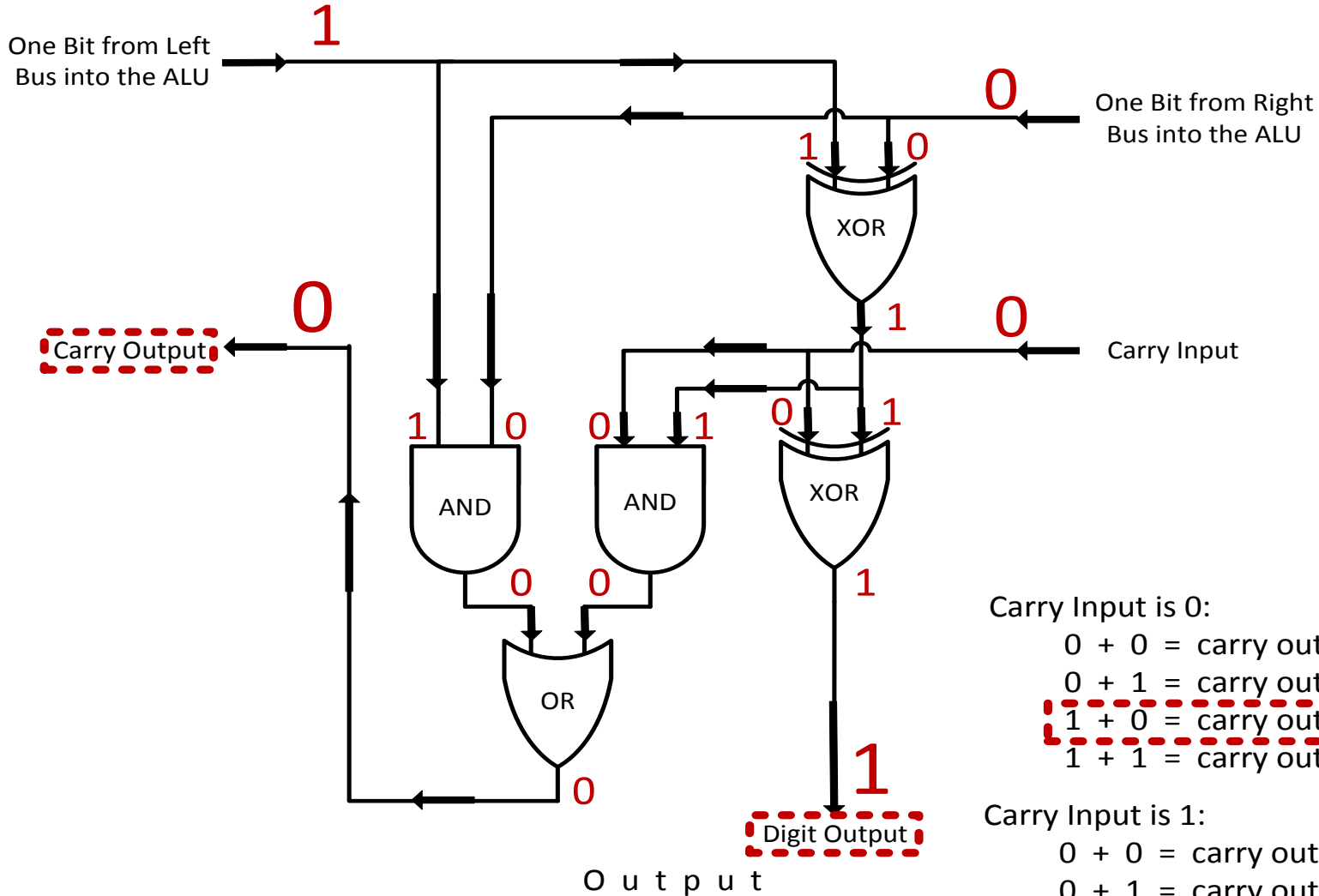

Conforms to the Binary Addition Results →

Carry Input is 0:

$0 + 0 = \text{carry out } 0 \text{ and sum digit } 0$

$0 + 1 = \text{carry out } 0 \text{ and sum digit } 1$

**$1 + 0 = \text{carry out } 0 \text{ and sum digit } 1$**

$1 + 1 = \text{carry out } 1 \text{ and sum digit } 0$

Carry Input is 1:

$0 + 0 = \text{carry out } 0 \text{ and sum digit } 1$

$0 + 1 = \text{carry out } 1 \text{ and sum digit } 0$

$1 + 0 = \text{carry out } 1 \text{ and sum digit } 0$

$1 + 1 = \text{carry out } 1 \text{ and sum digit } 1$

# Full Adder

Inputs from Left and Right Buses into the ALU

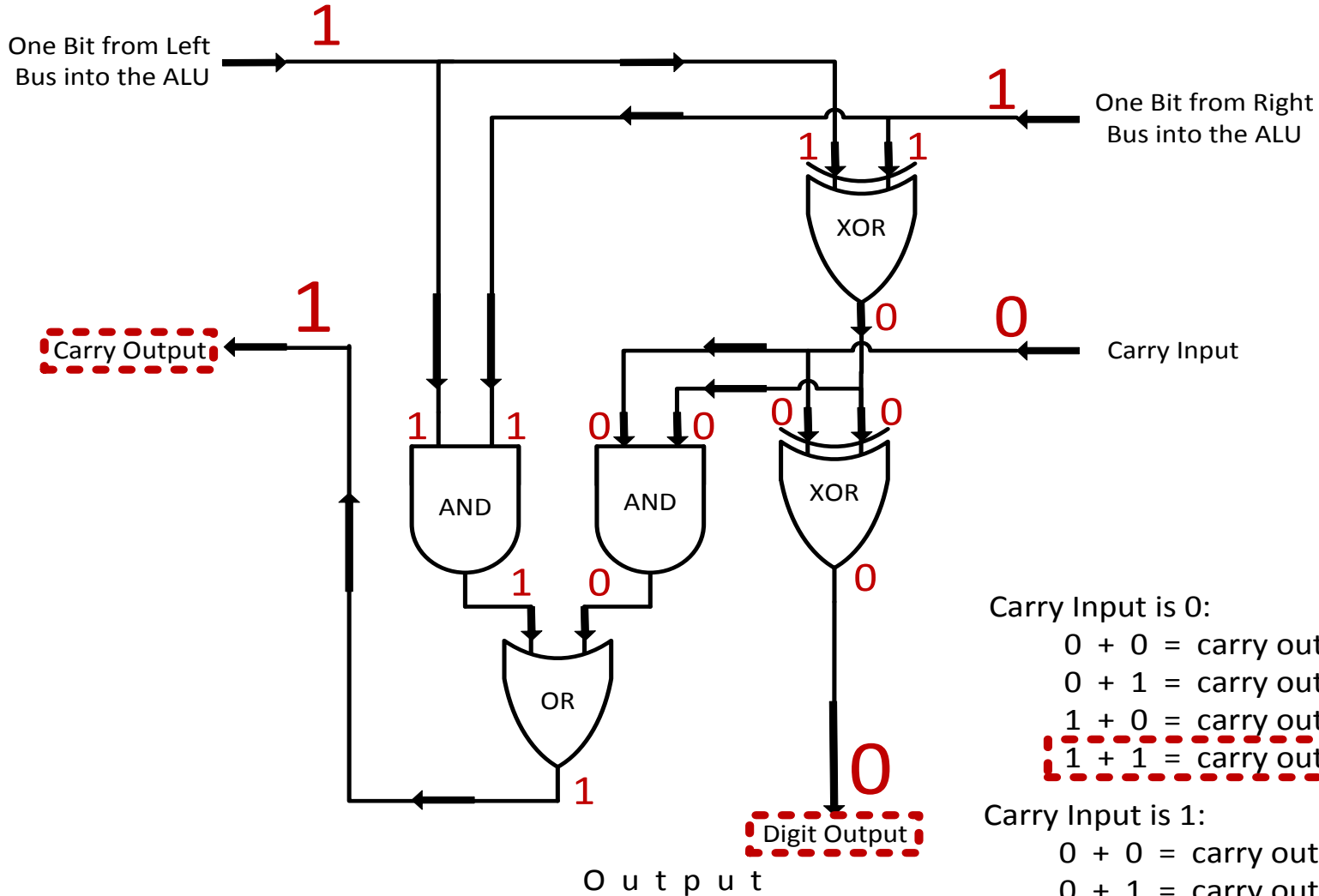

Carry Input is 0:

$0 + 0 = \text{carry out } 0 \text{ and sum digit } 0$

$0 + 1 = \text{carry out } 0 \text{ and sum digit } 1$

$1 + 0 = \text{carry out } 0 \text{ and sum digit } 1$

$1 + 1 = \text{carry out } 1 \text{ and sum digit } 0$

Carry Input is 1:

$0 + 0 = \text{carry out } 0 \text{ and sum digit } 1$

$0 + 1 = \text{carry out } 1 \text{ and sum digit } 0$

$1 + 0 = \text{carry out } 1 \text{ and sum digit } 0$

$1 + 1 = \text{carry out } 1 \text{ and sum digit } 1$

Conforms to the Binary Addition Results →

# Full Adder

Inputs from Left and Right Buses into the ALU

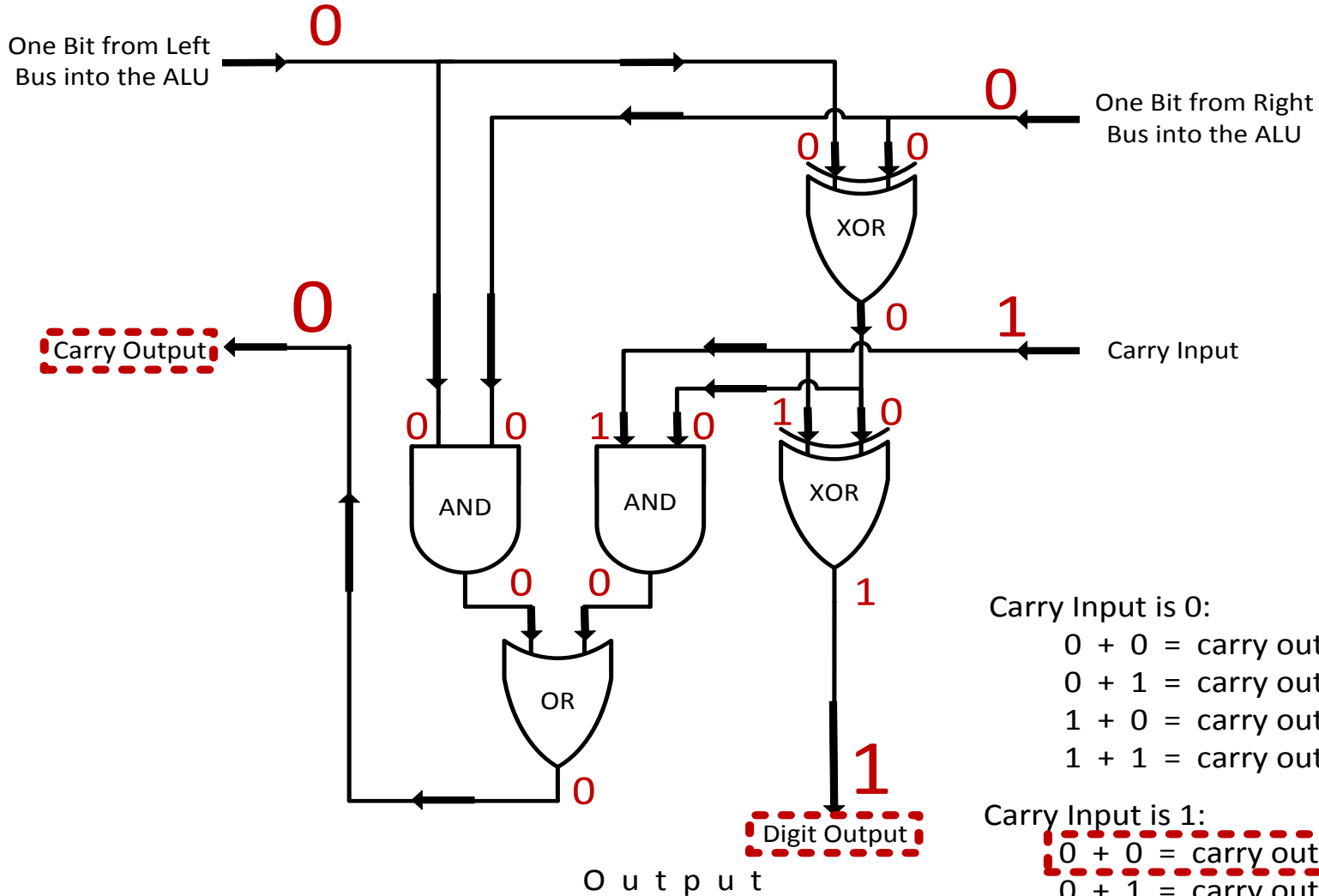

Carry Input is 0:

$0 + 0 = \text{carry out } 0 \text{ and sum digit } 0$

$0 + 1 = \text{carry out } 0 \text{ and sum digit } 1$

$1 + 0 = \text{carry out } 0 \text{ and sum digit } 1$

$1 + 1 = \text{carry out } 1 \text{ and sum digit } 0$

Carry Input is 1:

$0 + 0 = \text{carry out } 0 \text{ and sum digit } 1$

$0 + 1 = \text{carry out } 1 \text{ and sum digit } 0$

$1 + 0 = \text{carry out } 1 \text{ and sum digit } 0$

$1 + 1 = \text{carry out } 1 \text{ and sum digit } 1$

Conforms to the Binary Addition Results →

# Full Adder

Inputs from Left and Right Buses into the ALU

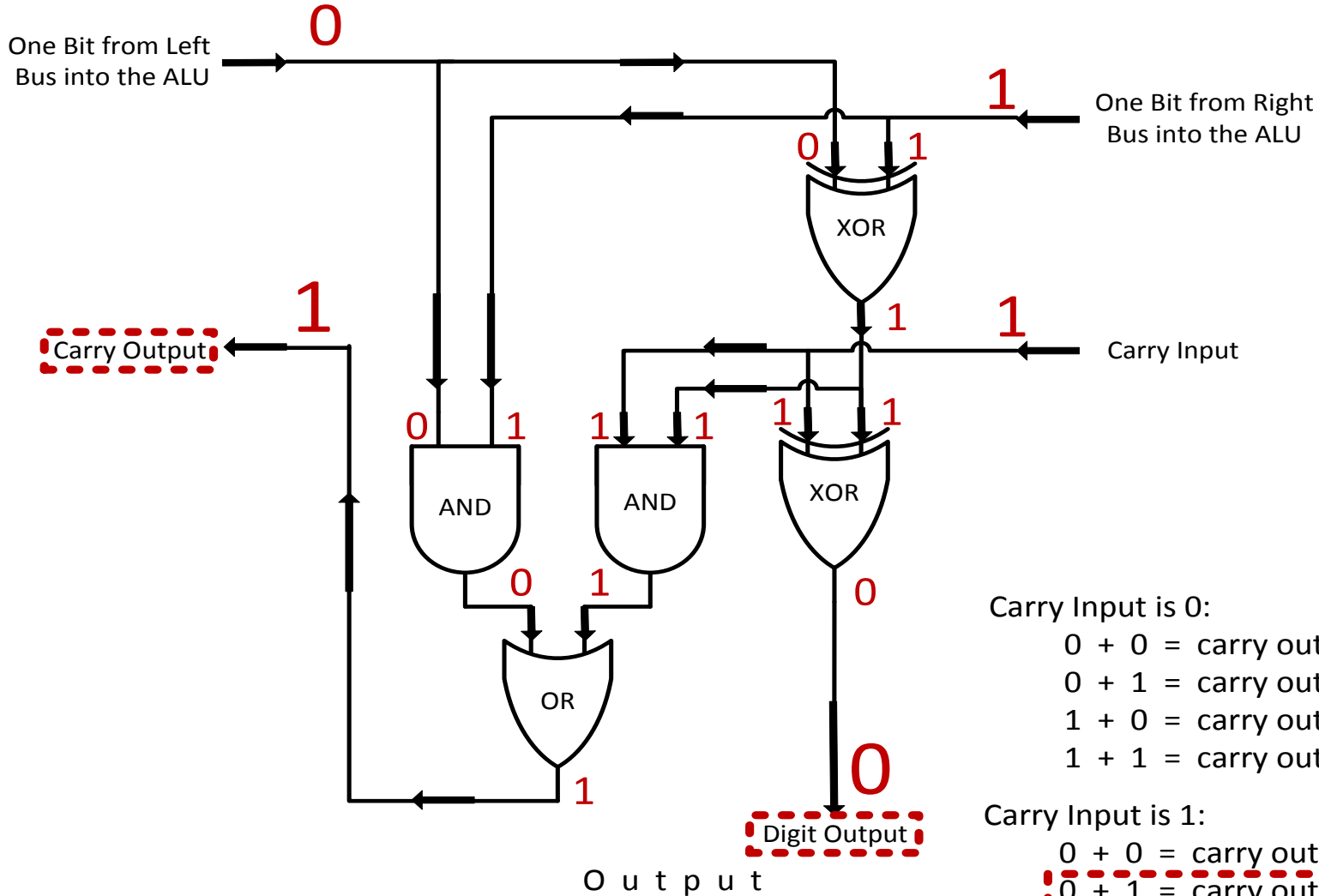

Carry Input is 0:

- $0 + 0 = \text{carry out } 0 \text{ and sum digit } 0$
- $0 + 1 = \text{carry out } 0 \text{ and sum digit } 1$
- $1 + 0 = \text{carry out } 0 \text{ and sum digit } 1$
- $1 + 1 = \text{carry out } 1 \text{ and sum digit } 0$

Carry Input is 1:

- $0 + 0 = \text{carry out } 0 \text{ and sum digit } 1$
- $0 + 1 = \text{carry out } 1 \text{ and sum digit } 0$
- $1 + 0 = \text{carry out } 1 \text{ and sum digit } 0$
- $1 + 1 = \text{carry out } 1 \text{ and sum digit } 1$

Conforms to the Binary Addition Results →

# Full Adder

Inputs from Left and Right Buses into the ALU

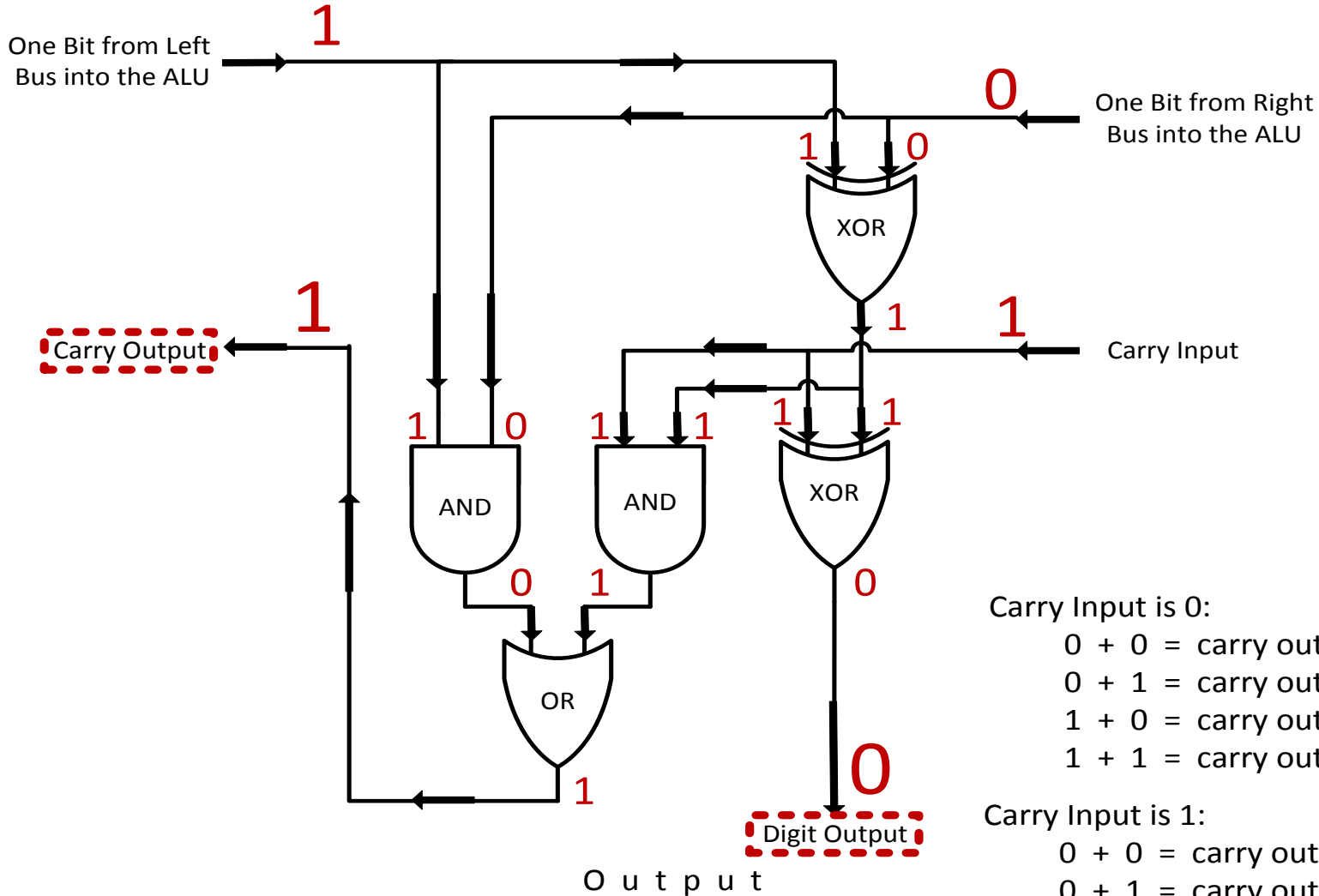

Carry Input is 0:

$0 + 0 = \text{carry out } 0 \text{ and sum digit } 0$

$0 + 1 = \text{carry out } 0 \text{ and sum digit } 1$

$1 + 0 = \text{carry out } 0 \text{ and sum digit } 1$

$1 + 1 = \text{carry out } 1 \text{ and sum digit } 0$

Carry Input is 1:

$0 + 0 = \text{carry out } 0 \text{ and sum digit } 1$

$0 + 1 = \text{carry out } 1 \text{ and sum digit } 0$

$1 + 0 = \text{carry out } 1 \text{ and sum digit } 0$

$1 + 1 = \text{carry out } 1 \text{ and sum digit } 1$

Conforms to the Binary Addition Results →



# Full Adder

Inputs from Left and Right Buses into the ALU

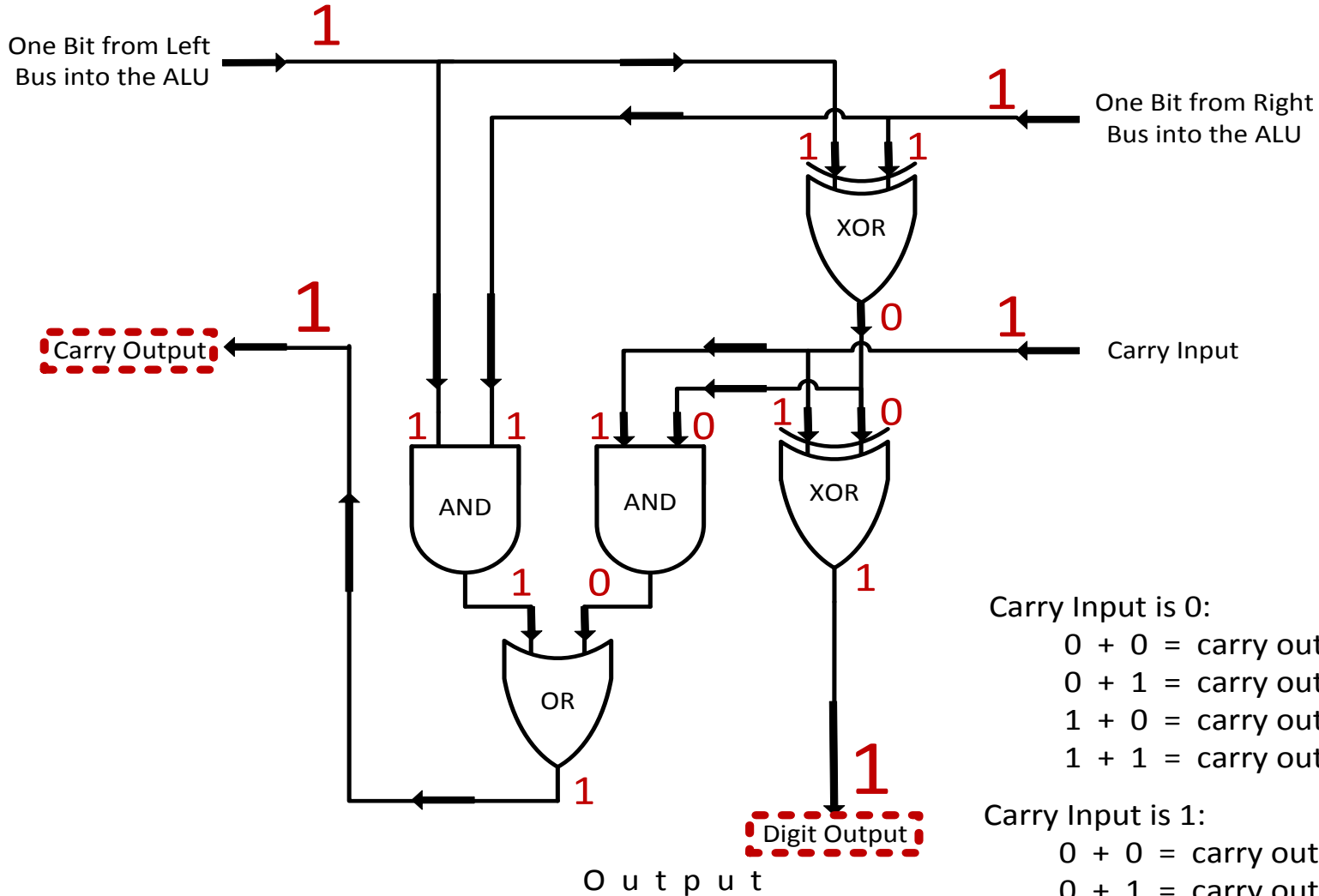

Carry Input is 0:

$0 + 0 = \text{carry out } 0 \text{ and sum digit } 0$

$0 + 1 = \text{carry out } 0 \text{ and sum digit } 1$

$1 + 0 = \text{carry out } 0 \text{ and sum digit } 1$

$1 + 1 = \text{carry out } 1 \text{ and sum digit } 0$

Carry Input is 1:

$0 + 0 = \text{carry out } 0 \text{ and sum digit } 1$

$0 + 1 = \text{carry out } 1 \text{ and sum digit } 0$

$1 + 0 = \text{carry out } 1 \text{ and sum digit } 0$

$1 + 1 = \text{carry out } 1 \text{ and sum digit } 1$

Conforms to the Binary Addition Results →

# Five Bit Adder

Inputs from Left and Right Busses into the ALU

Left bus into ALU

Right bus into ALU

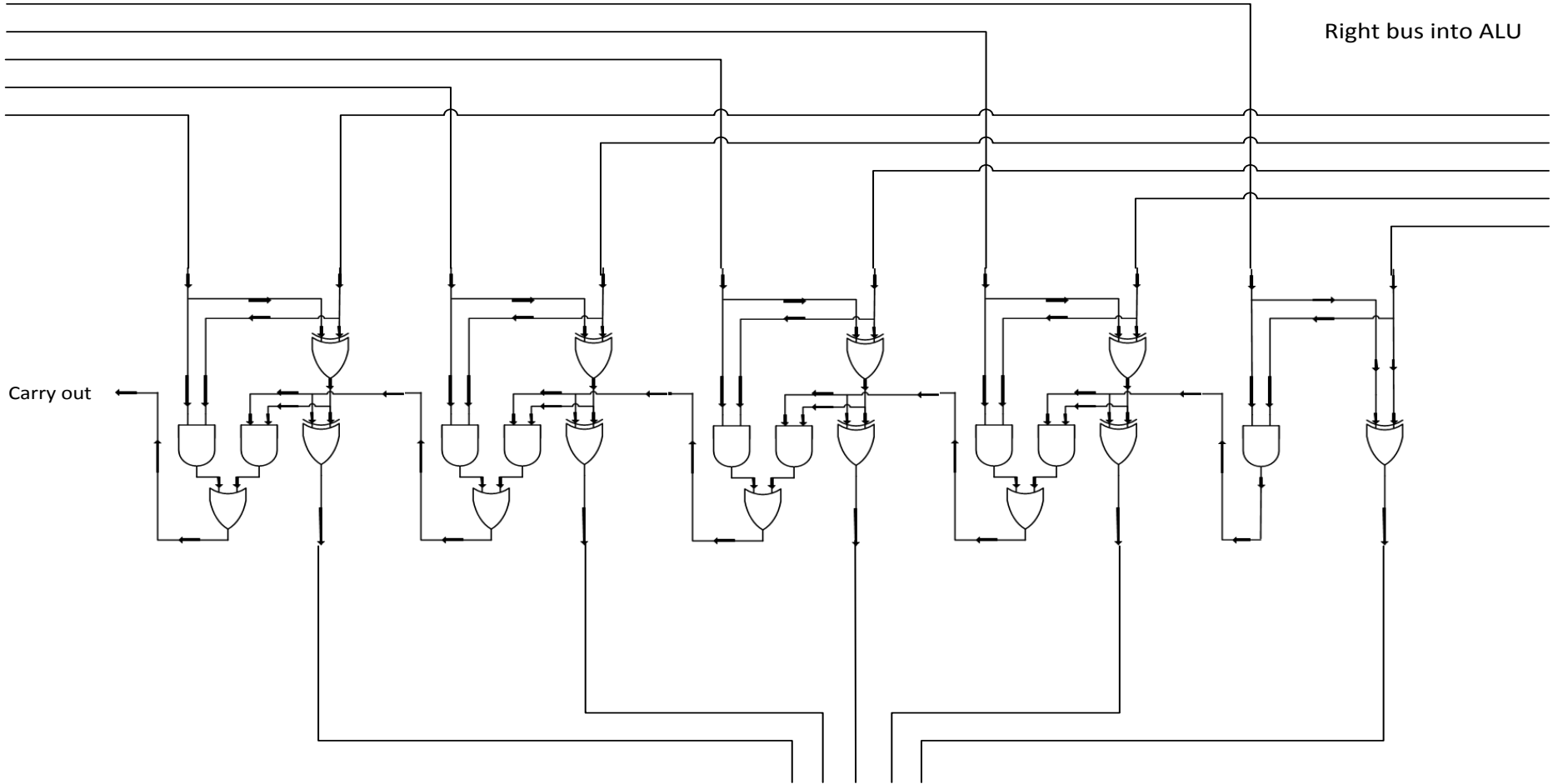

Carry out

O u t p u t

Accurate addition of two 5-bit binary numbers.

# Five Bit Adder

Inputs from Left and Right Busses into the ALU

Left bus into ALU

1 0 0 1 0

Right bus into ALU

0 0 1 1 1

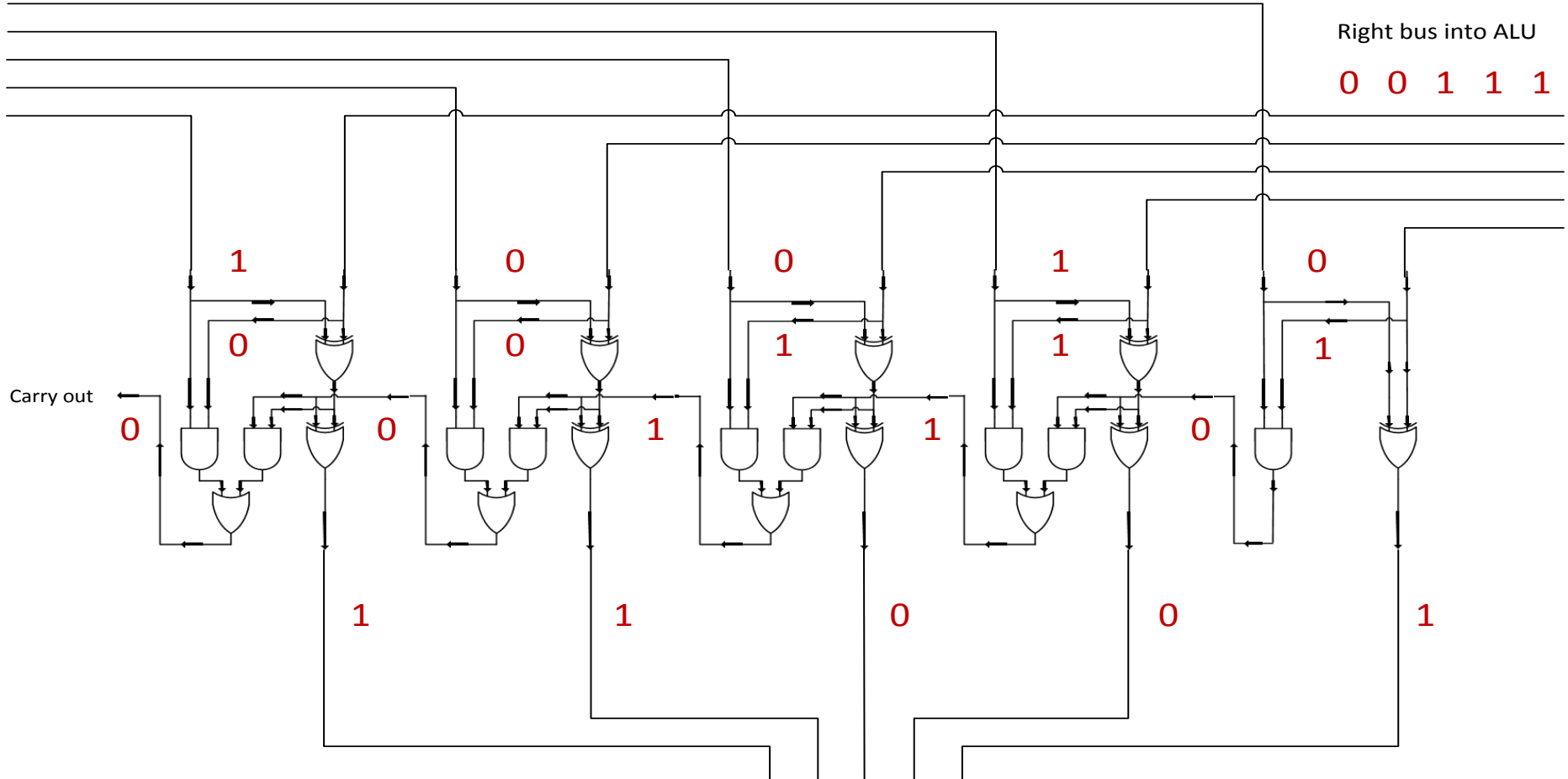

Carry out

0

1

0

1

0

0

1

0

1

0

1

1

0

0

1

1

Decimal equivalent

1 1 0 0 1

O u t p u t

1 0 0 1 0  
+ 0 0 1 1 1  

---

1 1 0 0 1

1 8  
+ 7  

---

2 5

Accurate addition of two 5-bit binary numbers.

**End of Presentation**